

Model/Modelo: PIACWMZ9082279A  
PIACWMZ1282279A

**PREMIUM**  
**LEVELLA®**

**MULTIZONE SYSTEM CASSETTE INDOOR UNIT**

SISTEMA MULTIZONA UNIDAD INTERIOR TIPO CASSETTE

# User's Manual & Installation Manual

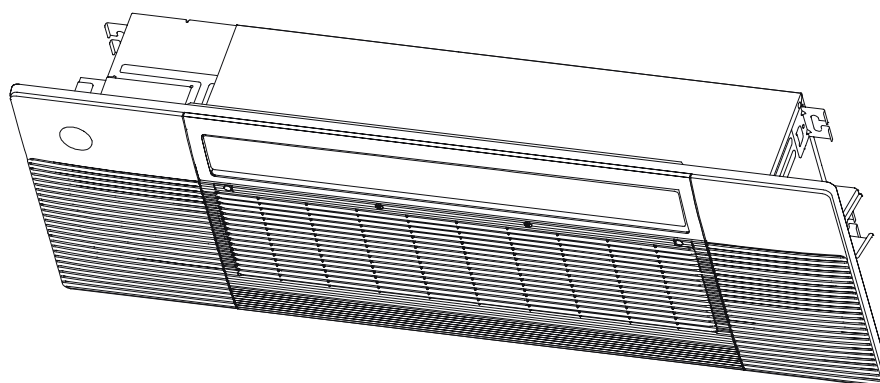

## **USER MANUAL / MANUAL DE INSTRUCCIONES**

Use and care manual. Important safeguards. This product is for domestic use only.

Manual de uso y cuidado. Precauciones importantes. Este producto es para uso doméstico únicamente.

# Table of Contents

Safety Precautions .....04

## Owner's Manual

Unit Specifications and Features .....08

1. Unit Parts .....08  
2. Operating temperature .....09  
3. Features .....10  
4. Energy Saving Tips .....11

Care and Maintenance .....12

Troubleshooting .....15

# Installation Manual

Accessories .....	17
Unit Parts .....	19
Indoor Unit Installation .....	20
1. Select installation location .....	20
2. Indoor Unit Installation.....	22
3. Optinal parts installation .....	25
Outdoor Unit Installation.....	27
1. Select installation location .....	27
2. Install drain joint .....	28
3. Anchor outdoor unit.....	28
Drainpipe Installation .....	31
Indoor Drainpipe Installation .....	31
Refrigerant Piping Connection .....	33
Electrical Connections .....	36
Air Evacuation .....	40
Electrical and Gas Leak Chechs .....	42
Panel Installation.....	43
1. Prepare and install ceiling .....	43
2. Panel Installation .....	43
3. Optinal parts installation.....	45
Test Run.....	46

# Safety Precautions

## Read Safety Precautions Before Operation and Installation

Incorrect installation due to ignoring instructions can cause serious damage or injury. The seriousness of potential damage or injuries is classified as either a **WARNING** or **CAUTION**.



### **WARNING**

This symbol indicates the possibility of personnel injury or loss of life.



### **CAUTION**

This symbol indicates the possibility of property damage or serious consequences.



### **WARNING**

- This appliance is not intended for use by persons (including children) with reduced physical, sensory or mental capabilities, or lack of experience and knowledge, unless they have been given supervision or instruction concerning use of the appliance by a person responsible for their safety. Children should be supervised to ensure that they do not play with the appliance.



### **WARNINGS FOR PRODUCT USE**

- If an abnormal situation arises (like a burning smell), immediately turn off the unit and disconnect the power. Call your dealer for instructions to avoid electric shock, fire or injury.
- Do not insert fingers, rods or other objects into the air inlet or outlet. This may cause injury, since the fan may be rotating at high speeds.
- Do not use flammable sprays such as hair spray, lacquer or paint near the unit. This may cause fire or combustion.
- Do not operate the air conditioner in places near or around combustible gases. Emitted gas may collect around the unit and cause explosion.
- Do not operate your air conditioner in a wet room such as a bathroom or laundry room. Too much exposure to water can cause electrical components to short circuit.
- Do not expose your body directly to cool air for a prolonged period of time.
- Do not allow children to play with the air conditioner. Children must be supervised around the unit at all times.
- If the air conditioner is used together with burners or other heating devices, thoroughly ventilate the room to avoid oxygen deficiency.
- In certain functional environments, such as kitchens, server rooms, etc., the use of specially designed air-conditioning units is highly recommended.
- Toxic fumes may be produced if the refrigerant in this unit comes into contact with naked flames (such as from a heater, gas stove/burners, or electric appliances).



## WARNINGS FOR PRODUCT USE

- Dispose of this unit's packaging carefully, so children cannot play with it. Packaging, especially plastic packaging, can be dangerous, can cause serious injury or death. Screws, staples and other metal packaging components can be sharp and should be disposed of carefully to avoid injury.
- Do not open or remove the unit's panel when the unit is powered on. Touching the unit's internal components while the unit is powered on can lead to electric shocks or injuries caused by moving parts such as the unit's fan.
- Do not spray any liquids onto the unit or allow any liquids to drip onto the unit.
- The refrigerant in this unit is safe and should not leak if the system is designed and installed properly. However, if a large amount of refrigerant leaks into a room, the oxygen concentration will decrease rapidly, which can cause serious injury or death. The refrigerant used in this unit is heavier than air, so the danger is greater in basements or other underground spaces. In the event of a refrigerant leak, turn off any devices that produce a naked flame and any heating devices, ventilate the room, and contact your supplier or service engineer immediately.

## CLEANING AND MAINTENANCE WARNINGS

- Turn off the device and disconnect the power before cleaning. Failure to do so can cause electrical shock.
- Do not clean the air conditioner with excessive amounts of water
- Do not clean the air conditioner with combustible cleaning agents. Combustible cleaning agents can cause fire or deformation.



## CAUTION

- Turn off the air conditioner and disconnect the power if you are not going to use it for a long time.
- Turn off and unplug the unit during storms.
- Make sure that water condensation can drain unhindered from the unit.
- Do not operate the air conditioner with wet hands. This may cause electric shock.
- Do not use device for any other purpose than its intended use.
- Do not climb onto or place objects on top of the outdoor unit.
- Do not allow the air conditioner to operate for long periods of time with doors or windows open, or if the humidity is very high.
- Some parts of the unit are sharp and can cause injury if touched. To prevent injury, when the unit is being serviced, gloves should be worn.



## ELECTRICAL WARNINGS

- Only use the specified power cord. If the power cord is damaged, it must be replaced by the manufacturer, its service agent or similarly qualified persons in order to avoid a hazard.



## ELECTRICAL WARNINGS

- Do not modify the length of the power supply cord or use an extension cord to power the unit.
- The product must be properly grounded at the time of installation, or electrical shock may occur.
- For all electrical work, follow all local and national wiring standards, regulations, and the Installation Manual. Connect cables tightly, and clamp them securely to prevent external forces from damaging the terminal. Improper electrical connections can overheat and cause fire, and may also cause shock. All electrical connections must be made according to the Electrical Connection Diagram located on the panels of the indoor and outdoor units.
- All wiring must be properly arranged to ensure that the control board cover can close properly. If the control board cover is not closed properly, it can lead to corrosion and cause the connection points on the terminal to heat up, catch fire, or cause electrical shock.
- Disconnection must be incorporated in the fixed wiring in accordance with the wiring rules.

## TAKE NOTE OF FUSE SPECIFICATIONS

The air conditioner's circuit board (PCB) is designed with a fuse to provide overcurrent protection. The specifications of the fuse are printed on the circuit board, examples of such are T5A/250VAC and T10A/250VAC.



## WARNINGS FOR PRODUCT INSTALLATION

- Installation must be performed by an authorized dealer or specialist. Defective installation can cause water leakage, electrical shock, or fire.
- Installation must be performed according to the installation instructions. Improper installation can cause water leakage, electrical shock, or fire.  
(In North America, installation must be performed in accordance with the requirement of NEC and CEC by authorized personnel only.)
- Contact an authorized service technician for repair or maintenance of this unit. This appliance shall be installed in accordance with national wiring regulations.
- Only use the included accessories, parts, and specified parts for installation. Using non-standard parts can cause water leakage, electrical shock, fire, and can cause the unit to fail.
- Install the unit in a firm location that can support the unit's weight. If the chosen location can not support the unit's weight, or the installation is not done properly, the unit may drop and cause serious injury and damage
- Install drainage piping according to the instructions in this manual. Improper drainage may cause water damage to your home and property
- For units that have an auxiliary electric heater, do not install the unit within 1 meter (3 feet) of any combustible materials
- Do not install the unit in a location that may be exposed to combustible gas leaks. If combustible gas accumulates around the unit, it may cause fire.
- Do not turn on the power until all work has been completed.



## ELECTRICAL WARNINGS

- When moving or relocating the air conditioner, consult experienced service technicians for disconnection and reinstallation of the unit.
- How to install the appliance to its support, please read the information for details in "indoor unit installation" and "outdoor unit installation" sections .

# Unit Specifications and Features

## Unit Parts

NOTE: Illustrations in this manual are for explanatory purposes. The actual shape of your indoor unit may be slightly different. The actual shape shall prevail.

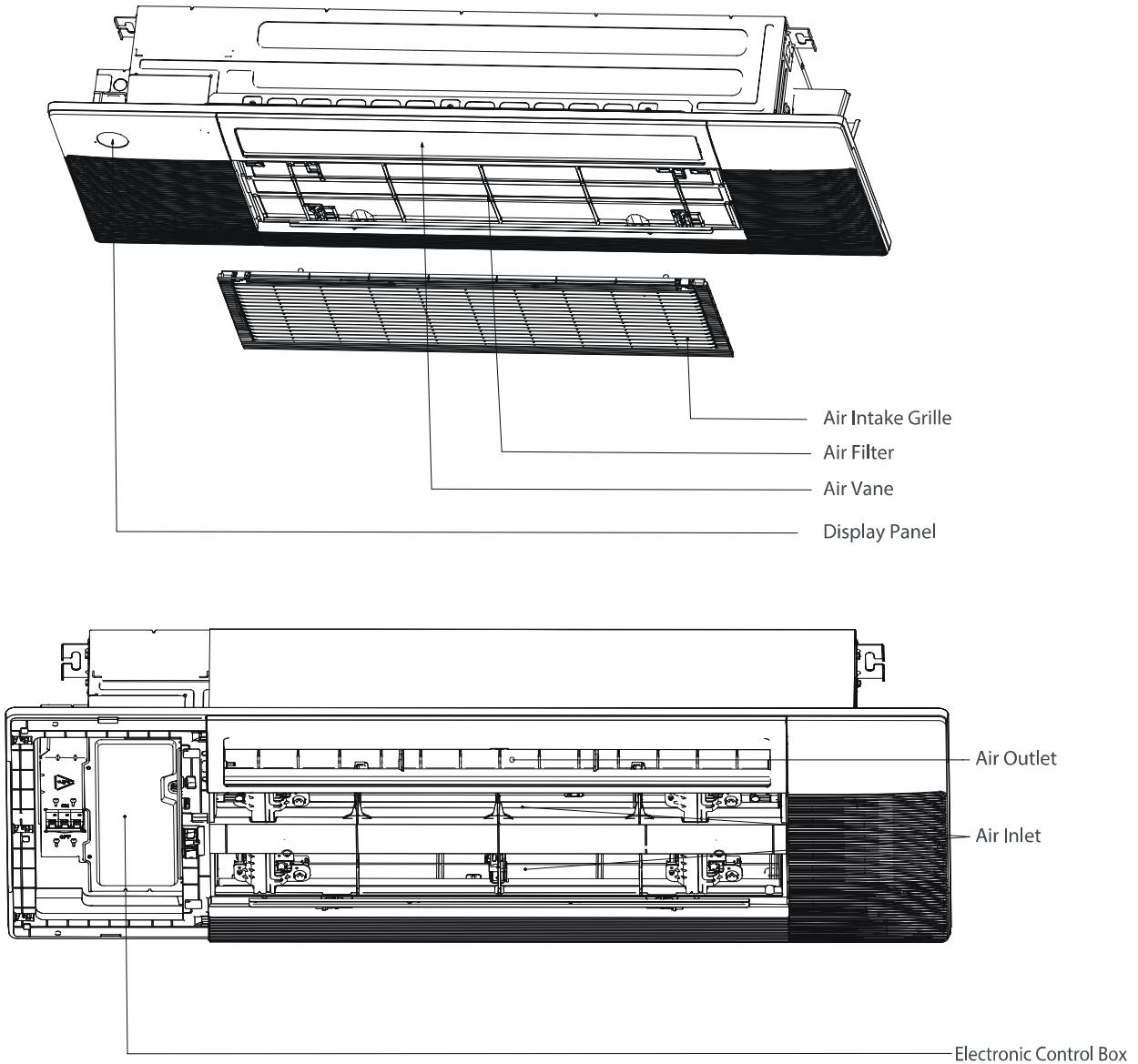







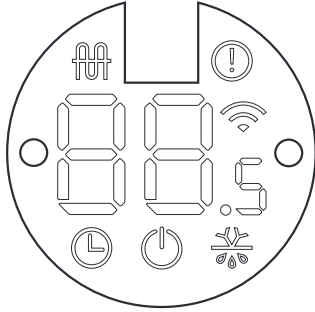

## Display panel

The display panel has one type and the appearance of the type is shown in below.



- " " when Electric heating feature is activated (Not available for this unit)
- " " when TIMER is set.
- " " when the unit is on.
- " " Alarm indicator.
- " " when Wireless Control feature is activated(some units)
- " " when pre-heating/defrost feature is activated.
- "88.5" Displays temperature, operation feature and Error codes:
- "FP" when 8°C heating feature is turned on
- "CL" when Active Clean feature is turned on
- "RP" when WiFi module enters AP mode(some units)
- "FC" when Forced cooling feature is turned on

## Operating temperature

When your air conditioner is used outside of the following temperature ranges, certain safety protection features may activate and cause the unit to disable.

### Inverter Split Type

	COOL mode	HEAT mode	DRY mode
Room Temperature	16°C - 32°C (61°F - 90°F)	0°C - 30°C (32°F - 86°F)	10°C - 32°C (50°F - 90°F)
Outdoor Temperature	-25°C - 50°C (-13°F - 122°F)	-25°C - 24°C (-13°F - 75°F)	0°C - 50°C (32°F - 122°F)

#### FOR OUTDOOR UNITS WITH AUXILIARY ELECTRIC HEATER

When outside temperature is below 0°C (32°F), we strongly recommend keeping the unit plugged in at all time to ensure smooth ongoing performance.

## NOTICE

Room relative humidity less than 80%. If the air conditioner operates in excess of this figure, the surface of the air conditioner may attract condensation. Please sets the vertical air flow louver to its maximum angle (vertically to the floor), and set HIGH fan mode.

To further optimize the performance of your unit, do the following:

- Keep doors and windows closed.
- Limit energy usage by using TIMER ON and TIMER OFF functions.
- Do not block air inlets or outlets.
- Regularly inspect and clean air filters.

## Features

### Default Setting

When the air conditioner restarts after a power failure, it will default to the factory settings (AUTO mode, AUTO fan, 24°C (76°F)). This may cause inconsistencies on the remote control and unit panel. Use your remote control to update the status.

### Auto-Restart

In case of power failure, the system will immediately stop. When power returns, the Operation light on the indoor unit will flash. To restart the unit, press the ON/OFF button on the remote control. If the system has an auto restart function, the unit will restart using the same settings.

### Three-minute protection feature

A protection feature prevents the air conditioner from being activated for approximately 3 minutes when it restarts immediately after operation.

### Louver Angle Memory Function

Some models are designed with a louver angle memory function. When the unit restarts after a power failure, the angle of the horizontal louvers will automatically return to the previous position.

The angle of the horizontal louver should not be set too small as condensation may form and drip into the machine. To reset the louver, press the manual button, which will reset the horizontal louver settings.

### Refrigerant Leak Detection System (Multi-Zone Systems models do not have this function)

In the event of a refrigerant leak, the LED DISPLAY will display refrigerant leak error code and the LED indicator light will flash.

### Sleep Operation

The SLEEP function is used to decrease energy use while you sleep (and don't need the same temperature settings to stay comfortable). This function can only be activated via remote control. And the Sleep function is not available in FAN or DRY mode.

Press the SLEEP button when you are ready to go to sleep. When in COOL mode, the unit will increase the temperature by 1°C (2°F) after 1 hour, and will increase an additional 1°C (2°F) after another hour.

When in HEAT mode, the unit will decrease the temperature by 1°C (2°F) after 1 hour, and will decrease an additional 1°C (2°F) after another hour.

The sleep feature will stop after 8 hours and the system will keep running with final situation.

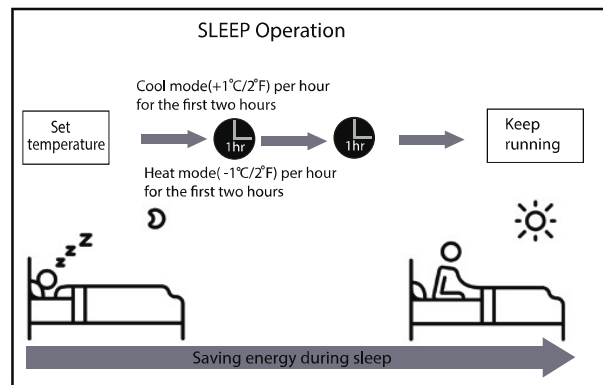

Active Clean function (Multi-Zone Systems models do not have this function)

The Active Clean Technology washes away dust when it adheres to the heat exchanger by automatically freezing and then rapidly thawing the frost. A “pi-pi” sound will be heard.

The Active clean operation is used to produce more condensed water to improve the cleaning effect, and the cold air will blow out. After cleaning, the internal wind wheel then keeps operating with hot air to blow-dry the evaporator, thus keeping the inside clean.

- When this function is turned on, the indoor unit display window appears “CL ” , after 20 to 130 minutes, the unit will turn off automatically and cancel Active Clean function.

- For some units, the system will start high temperature cleaning process, and the temperature of air outlet is very high. Please keep away from it. And this would lead to the rising of the room temperature .

### Lifting panel operation

In the stand-by mode, press the “Mode” and “Down” buttons for 3 seconds at the same time, the remote controller enters the setting panel state, and the remote controller displays "F2". When setting the panel status, press the “Up” or “Down” buttons of the remote controller to control the rise or fall of the grille, and press any other button to exit the setting.

The up and down height of the panel can reach a maximum of 1.5 meters. During the decline, if the grille is raised by the obstacles, it will stop. During the ascending process, if the grille is blocked and does not rise to the correct height or a finger is pinched, it will automatically descend after a period of time and then ascend. If the grille is blocked for the third times, then the display panel will report an error and prompt for manual processing.

### Breeze Away

This feature avoids direct air flow blowing on the body and make you feel indulging in silky coolness.

## Energy Saving Tips

- DO NOT set the unit to excessive temperature levels.
- While cooling, close the curtains to avoid direct sunlight.
- Doors and windows should be kept closed to keep cool or warm air in the room.
- DO NOT place objects near the air inlet and outlet of the unit.
- Clean the air filter every two weeks.
- Adjust louvers properly and avoid direct airflow.
- Closing curtains during heating also helps keep the heat in.
- Doors and windows should be kept closed.

# Care and Maintenance

## Cleaning Your Indoor Unit

### BEFORE CLEANING OR MAINTENANCE

REMEMBER TO DISCONNECT THE POWER BEFORE CLEANING OR MAINTENANCE, EXCEPT FOR CLEANING AIR FILTER. TURN THE CIRCUIT BREAKER OF THE INDOOR UNIT TO OFF IS NOT A KIND OF POWER DISCONNECTION.

- Contact an authorized service technician for repair or maintenance. Improper repair and maintenance may cause water leakage, electrical shock, or fire, and may void your warranty.
- DO NOT substitute a blown fuse with a higher or lower amperage rating fuse, as this may cause circuit damage or an electrical fire.
- Make sure the drain hose is set up according to the instructions. Failure to do so could cause leakage and result in personal property damage, fire and electric shock.
- Make sure that all wires are connected properly. Failure to connect wires according to instructions can result in electrical shock or fire.

### CAUTION

- Only use a soft, dry cloth to wipe the unit clean. If the unit is especially dirty, you can use a cloth soaked in warm water to wipe it clean.
- Do not use chemicals or chemically treated cloths to clean the unit.
- Do not use benzene, paint thinner, polishing powder or other solvents to clean the unit. They can cause the plastic surface to crack or deform.
- Do not use water hotter than 40°C (104°F) to clean the front panel. This can cause the panel to deform or become discolored.
- DO NOT wash the unit under running water. Doing so creates an electrical hazard. Clean the unit using a damp, lint-free cloth and neutral detergent. Dry the unit with a dry, lint-free cloth.

### WARNING: DO NOT REMOVE OR CLEAN THE FILTER BY YOURSELF

Removing and cleaning the filter can be dangerous. Removal and maintenance must be performed by a certified technician.

## Cleaning Your Air Filter

The filter prevents dust and other particles from entering the indoor unit. Dust buildup can reduce the efficiency of the air conditioner. For optimum efficiency, clean the air filter every two weeks or more frequently if you live in a dusty area. Replace the filter with a new one if it's heavily clogged and cannot be cleaned.

### NOTICE

In households with animals, you will have to periodically wipe down the grille to prevent animal hair blocking airflow.

### Model A

1. In the stand-by mode, press the "MODE" and "DOWN" buttons on the remote controller at the same time for 3 seconds, the remote controller enters the panel-setting state, the remote controller displays "F2".
2. Then press "DOWN" button on the remote controller, the air grille automatically goes down. When it stops, pick up the air filter.

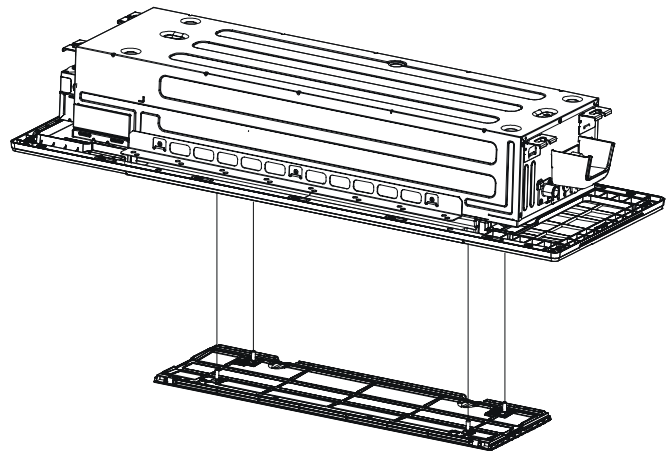

- a. Hold the upper edge of the filter with both hands. Gently turn and lift until the upper edge is free from the wire rope.
- b. Lift the filter and move it forward slightly until the filter is separated from the 4 wire ropes.
- c. Move the filter to the right until it is separated from the air grille, and then the filter can be taken out.

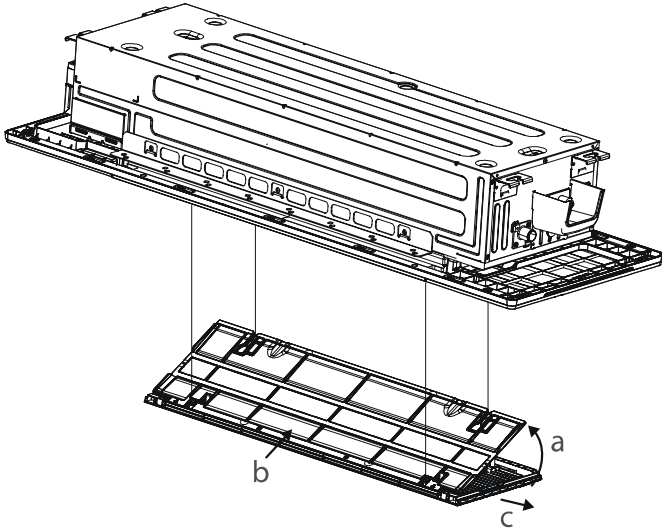

**Model B**

1. Press the circular position to open the two screw covers, then remove the two screws.

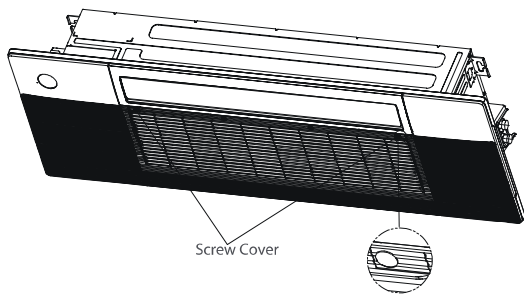

2. Hold and open the air grille, then take out the air filter.

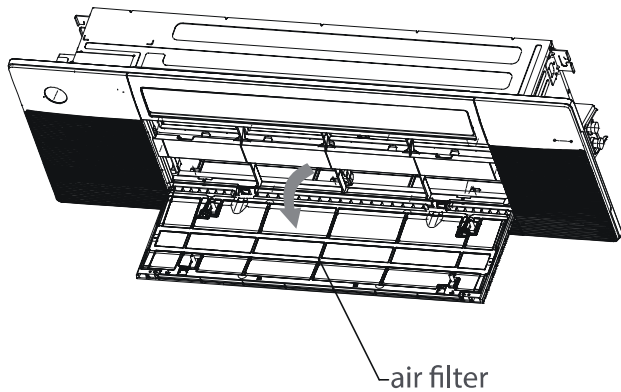

3. Clean the air filter  
Dusts will accumulate on the filter along with the unit operation, and need to be removed from the filter, or the unit would not function effectively. Clean the filter every two weeks when you use the unit regularly.

Clean the air filter with a vacuum cleaner or water.

- a. The air intake side should face up when using a vacuum cleaner.

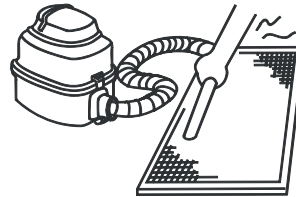

- b. The air intake side should face down when using clean water.

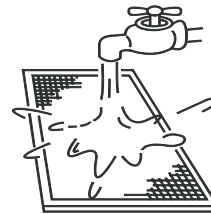

For excessive dusts, use a soft brush and natural detergent to clean it and dry in a cool place.

**CAUTION**

- Do not dry out the air filter under direct sunshine or with fire.
- The air filter should be installed before the unit body installation.

4. Re-install the air filter.
5. Press "UP" button on the remote controller to reset the air grille. (Applicable to model A)  
Re-install the air grille by fixing the two screws and close the two screw covers. (Applicable to model B)

**CAUTION**

- Before changing the filter or cleaning, turn off the unit .
- When removing filter, do not touch metal parts in the unit. The sharp metal edges can hurt you.
- Do not use water to clean the inside of the indoor unit. This can destroy insulation and cause electrical shock.
- Do not expose filter to direct sunlight when drying. This can shrink the filter.
- Any maintenance and cleaning of outdoor unit should be performed by an authorized dealer or a licensed service provider.
- Any unit repairs should be performed by an authorized dealer or a licensed service provider.
- When the air grille is rising, please do not hinder the grille from rising with your hands or other objects.
- Please do not pull the wire rope, if necessary, please contact the local customer service team.

**Maintenance – Long Periods of Non-Use**

If you plan not to use your air conditioner for an extended period of time, do the following:

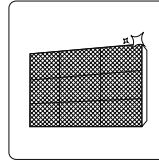

Clean all filters

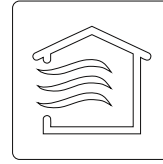

Turn on FAN function until unit dries out completely

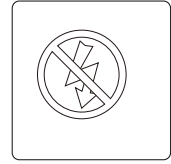

Turn off the unit and disconnect the power

**Maintenance – Pre-Season Inspection**

After long periods of non-use, or before periods of frequent use, do the following:

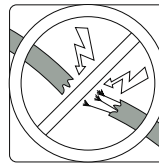

Check for damaged wires

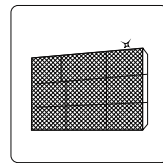

Clean all filters



Check for leaks

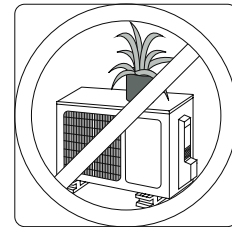
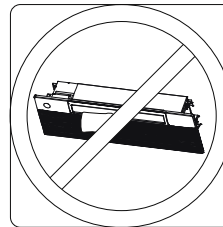

Make sure nothing is blocking all air inlets and outlets



# Troubleshooting



## SAFETY PRECAUTIONS

If any of the following conditions occurs, turn off your unit immediately!

- The power cord is damaged or abnormally warm.
- You smell a burning odor.
- The unit emits loud or abnormal sounds.
- A power fuse blows or the circuit breaker frequently trips.
- Water or other objects fall into or out of the unit.

**DO NOT ATTEMPT TO FIX THESE YOURSELF! CONTACT AN AUTHORIZED SERVICE PROVIDER IMMEDIATELY!**

## Common Issues

The following problems are not a malfunction and in most situations will not require repairs.

Issue	Possible Causes
Unit does not turn on when pressing ON/OFF button	The Unit has a 3-minute protection feature that prevents the unit from overloading. The unit cannot be restarted within three minutes of being turned off.
	Cooling and Heating Models: If the Operation light and PRE-DEF (Pre-heating/Defrost) indicators are lit up, the outdoor temperature is too cold and the unit's anti-cold wind is activated in order to defrost the unit.
	In Cooling-only Models: If the "Fan Only" indicator is lit up, the outdoor temperature is too cold and the unit's anti-freeze protection is activated in order to defrost the unit.
The unit changes from COOL/HEAT mode to FAN mode	The unit may change its setting to prevent frost from forming on the unit. Once the temperature increases, the unit will start operating in the previously selected mode again.
	The set temperature has been reached, at which point the unit turns off the compressor. The unit will continue operating when the temperature fluctuates again.
The indoor unit emits white mist	In humid regions, a large temperature difference between the room's air and the conditioned air can cause white mist.
Both the indoor and outdoor units emit white mist	When the unit restarts in HEAT mode after defrosting, white mist may be emitted due to moisture generated from the defrosting process.
The indoor unit makes noises	A squeaking sound is heard when the system is OFF or in COOL mode. The noise is also heard when the drain pump (optional) is in operation.
	A squeaking sound may occur after running the unit in HEAT mode due to expansion and contraction of the unit's plastic parts.
Both the indoor unit and outdoor unit make noises	Low hissing sound during operation: This is normal and is caused by refrigerant gas flowing through both indoor and outdoor units.
	Low hissing sound when the system starts, has just stopped running, or is defrosting: This noise is normal and is caused by the refrigerant gas stopping or changing direction.
	Squeaking sound: Normal expansion and contraction of plastic and metal parts caused by temperature changes during operation can cause squeaking noises.

Issue	Possible Causes
The outdoor unit makes noises	The unit will make different sounds based on its current operating mode.
Dust is emitted from either the indoor or outdoor unit	The unit may accumulate dust during extended periods of non-use, which will be emitted when the unit is turned on. This can be mitigated by covering the unit during long periods of inactivity.
The unit emits a bad odor	The unit may absorb odors from the environment (such as furniture, cooking, cigarettes, etc.) which will be emitted during operations.
	The unit's filters have become moldy and should be cleaned.
The fan of the outdoor unit does not operate	During operation, the fan speed is controlled to optimize product operation.

## NOTICE

If problem persists, contact a local dealer or your nearest customer service center. Provide them with a detailed description of the unit malfunction as well as your model number.

## Troubleshooting

When troubles occur, please check the following points before contacting a repair company.

Problem	Possible Causes	Solution
Poor Cooling Performance	Temperature setting may be higher than ambient room temperature	Lower the temperature setting
	The heat exchanger on the indoor or outdoor unit is dirty	Clean the affected heat exchanger
	The air filter is dirty	Remove the filter and clean it according to instructions
	The air inlet or outlet of either unit is blocked	Turn the unit off, remove the obstruction and turn it back on
	Doors and windows are open	Make sure that all doors and windows are closed while operating the unit
	Excessive heat is generated by sunlight	Close windows and curtains during periods of high heat or bright sunshine
	Too many sources of heat in the room (people, computers, electronics, etc.)	Reduce amount of heat sources
	Low refrigerant due to leak or long-term use	Check for leaks, re-seal if necessary and top off refrigerant





Problem	Possible Causes	Solution
The unit is not working	Power failure	Wait for the power to be restored
	The power is turned off	Turn on the power
	The fuse is burned out	Replace the fuse
	The Unit's 3-minute protection has been activated	Wait three minutes after restarting the unit
	Timer is activated	Turn timer off
The unit starts and stops frequently	There's too much or too little refrigerant in the system	Check for leaks and recharge the system with refrigerant.
	Incompressible gas or moisture has entered the system.	Evacuate and recharge the system with refrigerant
	System circuit is blocked	Determine which circuit is blocked and replace the malfunctioning piece of equipment
	The compressor is broken	Replace the compressor
	The voltage is too high or too low	Install a manostat to regulate the voltage
Poor heating performance	Cold air is entering through doors and windows	Make sure that all doors and windows are closed during use
	Low refrigerant due to leak or long-term use	Check for leaks, re-seal if necessary and top off refrigerant

## Accessories



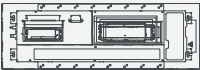







The air conditioning system comes with the following accessories. Use all of the installation parts and accessories to install the air conditioner. Improper installation may result in water leakage, electrical shock and fire, or equipment failure.

Verify that the air conditioner includes the following accessories.

Name	Shape	Q'ty(pc)
Manual		1
Installation cardboard template		1
Remote controller		1
AAA Battery		2

# Accessories

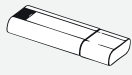
Accessories

Name	Shape	Q'ty(pc)	
Cable tie		6	
Drainpipe adaptor		1	
Screw kits (ST8*50 , M4*22 , ST3.9*16 , ST4.8*12,ST3.9*10)		1 (8,8,2,2,3)	
Water receiver		1	
Seal		1	
Drain joint		1	
Wire controller (optional)		1	
Rubber ring		1	
WiFi controller (optional)		1	
Panel		1	
Copper nut		2	

Name	Shape	Q'ty(pc)	Note
Connecting pipe assembly	Liquid side	Φ 6.35 (1/4 in)	To purchase based on actual project requirements.
	Gas side	Φ 9.52 (3/8in)	
		Φ 12.7 (1/2in)	
			Parts you must purchase separately. Consult the dealer about the proper pipe size of the unit you purchased.